

Alternative Antriebskonzepte

Alternative powertrain concepts

Konzeptentwicklung

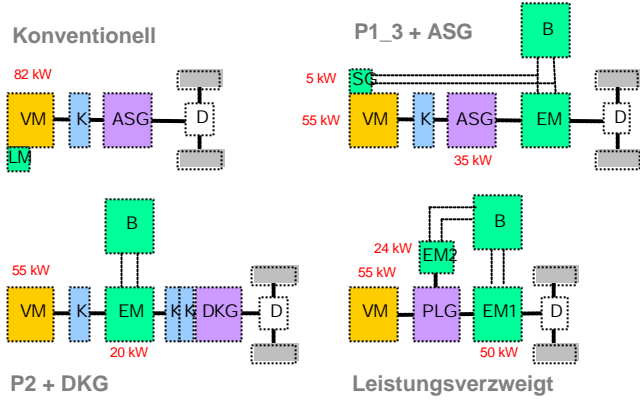

Simulation

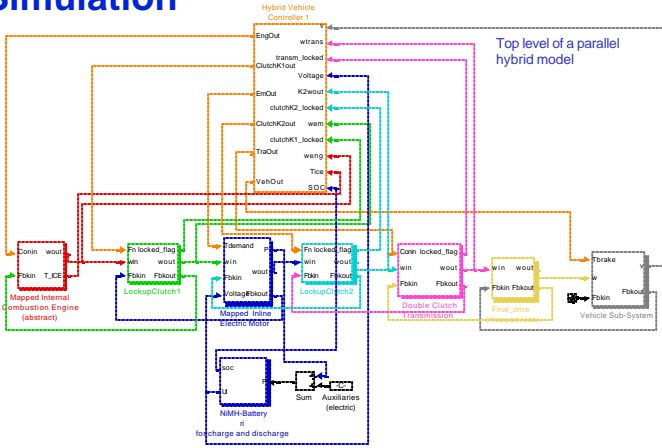

Betriebsstrategien

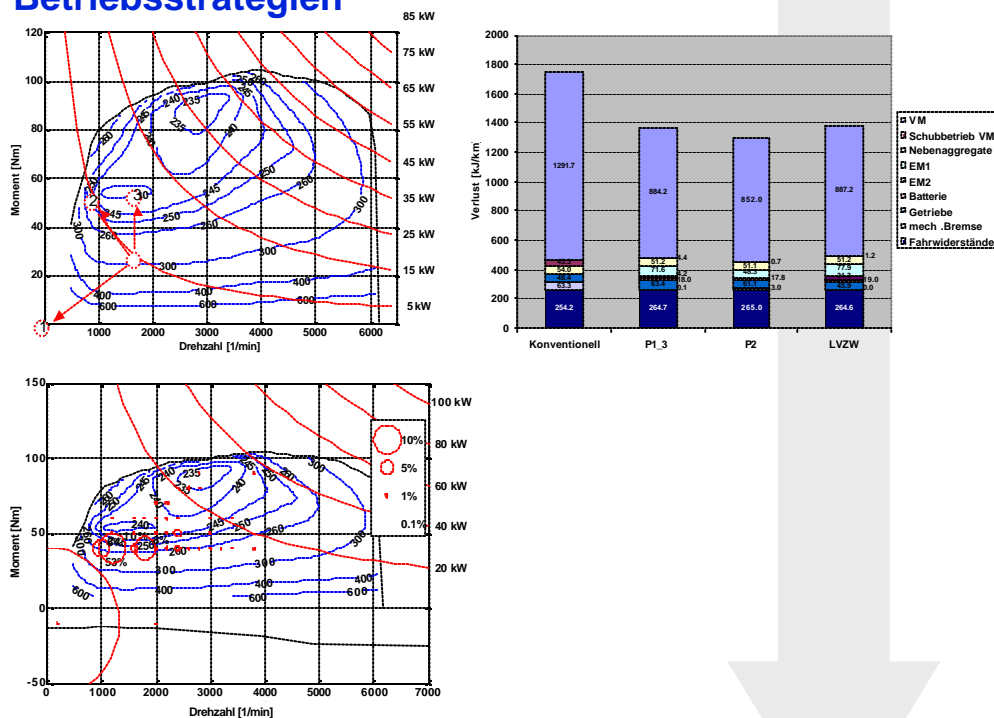

- Konzeptentwicklung
- Simulation
- Betriebsstrategien
- Controller Hard-/Software
- Prototypen-Fahrzeuge
- Versuch und Testing
- Technische Marktanalyse



Entwicklungsprozess

Technische Marktanalyse

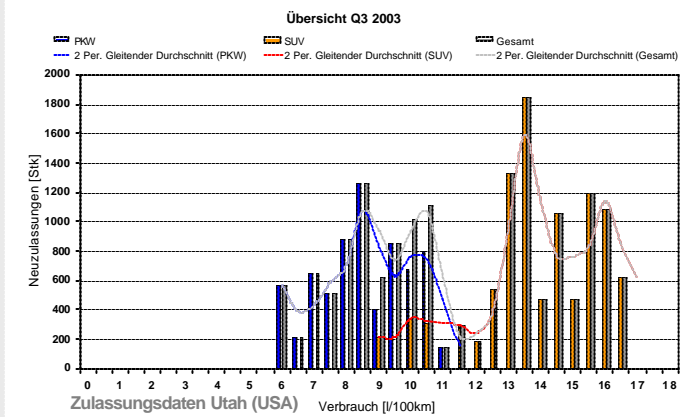
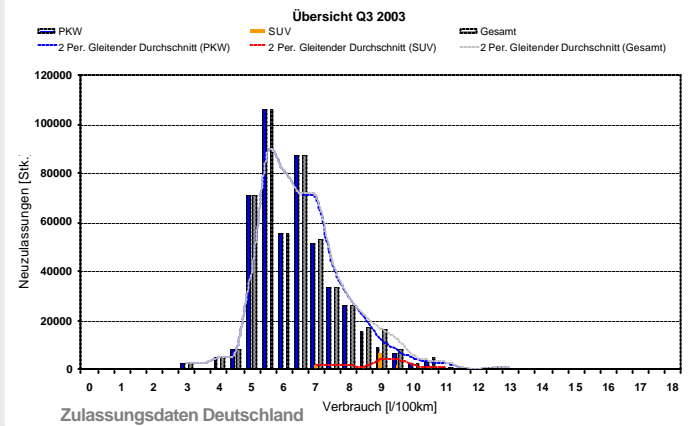

Marketing strategy will be crucial to alternative powertrains' success

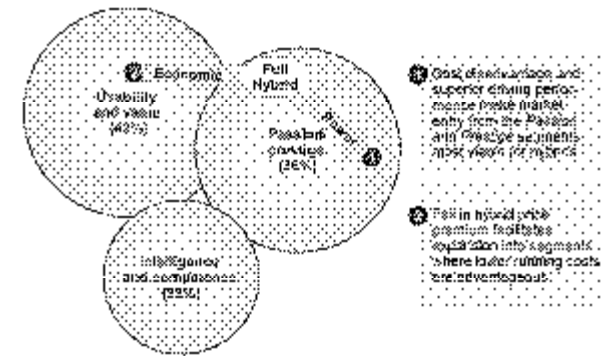

Porsche, Volkswagen, Audi – Ein gemeinsames Hybrid-Konzept

“Full-Hybrid” mit Kraftstoffverbrauchsreduktion von ca. 15 %

